

Top View

10'

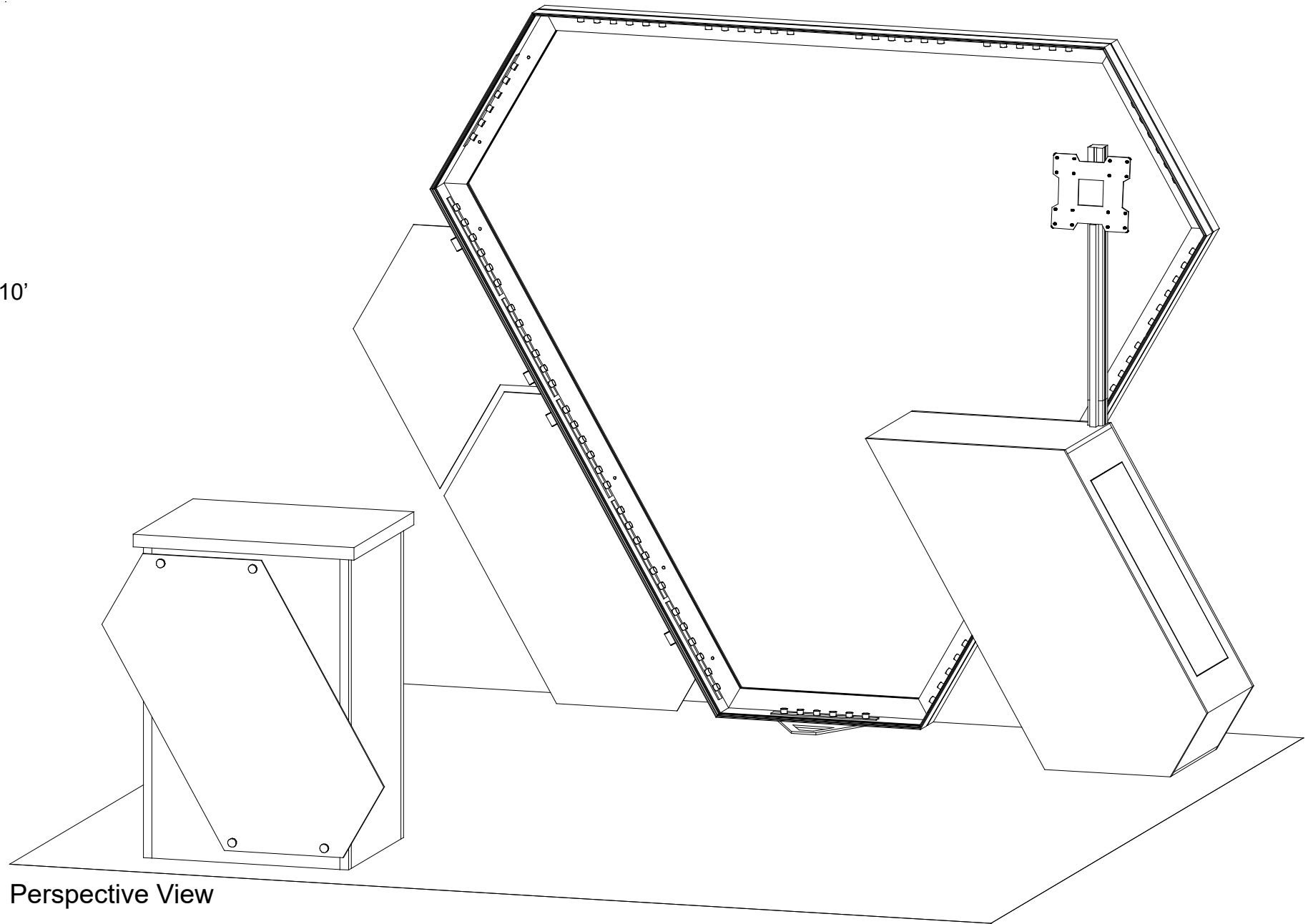

Perspective View

SETUP INSTRUCTIONS

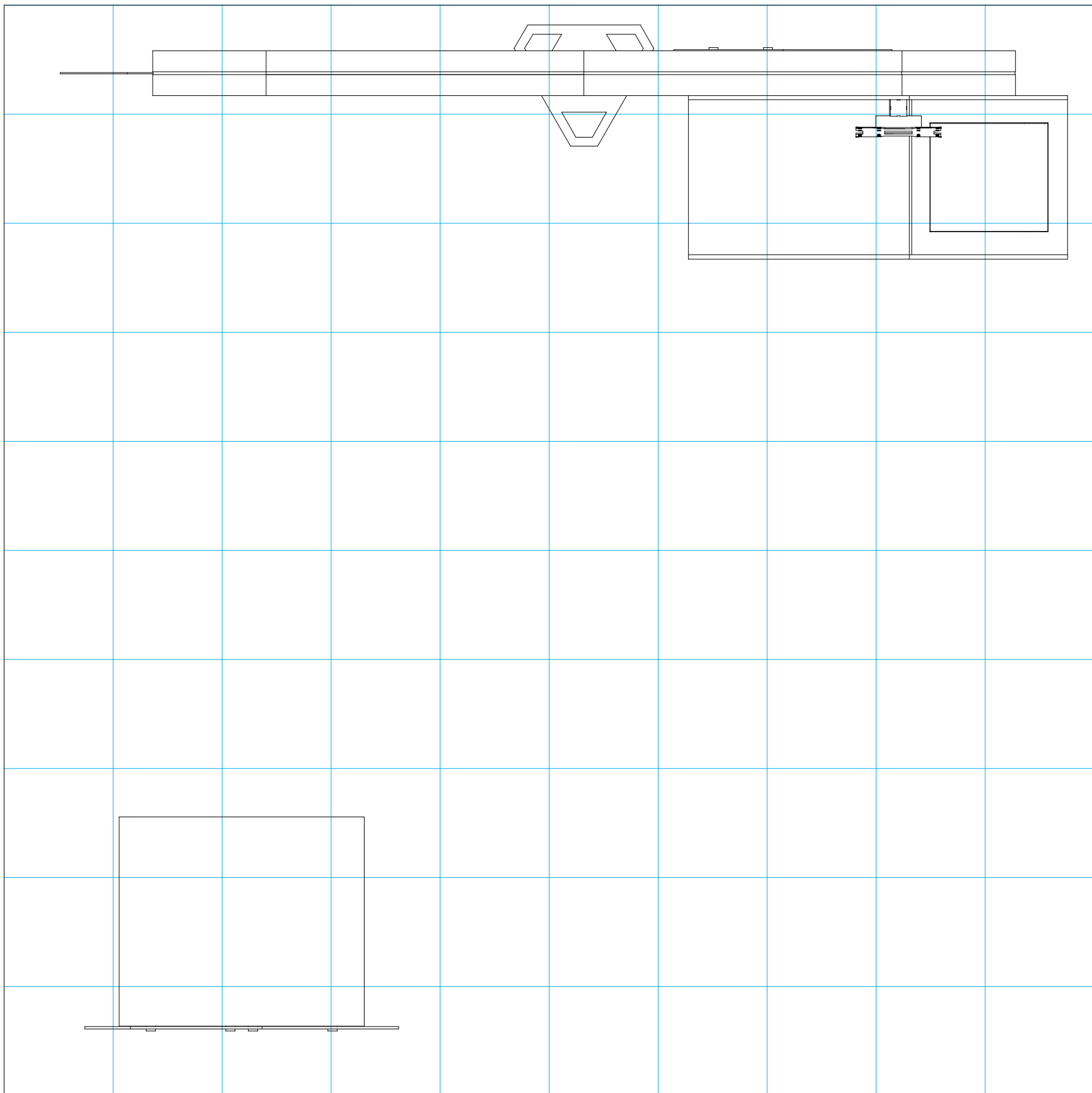

= 1 sq foot

General Setup Instructions

- Read entire setup instruction manual prior to unpacking parts and pieces.
- The setup instructions are created specifically for this configuration.
- Setup instructions are laid out sequentially in steps, including exploded views with detailed explanation for assembly.

Cleaning & Packing

- For Cleaning Metal, Plex, & Laminate Parts: Use a **MILD NON-ABRASIVE** cleanser and soft cloth/paper towel to clean all surfaces.
- Keep exhibit components away from heat and prolonged sun exposure. **Heat and UV exposure will warp and fade components.**
- Retain all provided Packing Materials. All provided packing materials are for ease of repacking & component protection.

Disassembly

- For loss prevention, tighten all set screws and locks during disassembly.

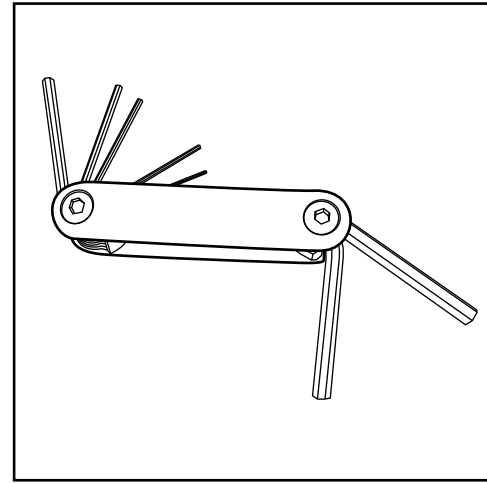

Hex Tool - Essential for Assembly

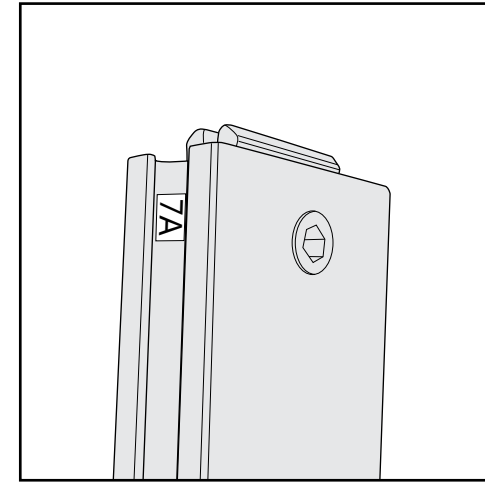

Part Identification - Numbering

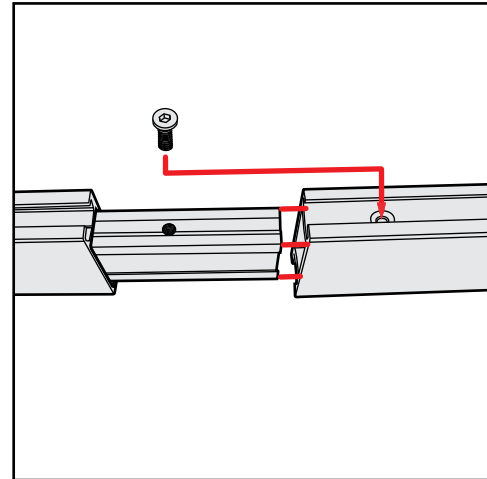

Spline Connection

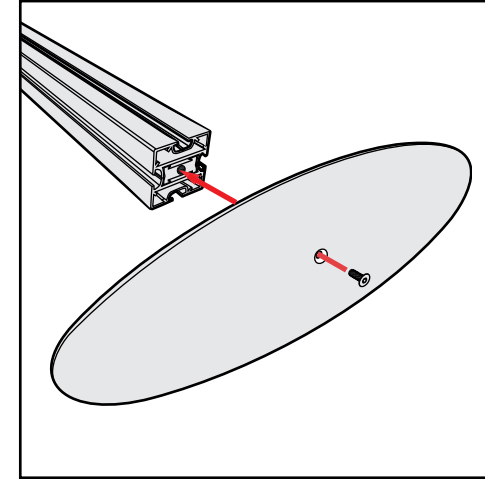

Base Plate & Extrusion Connection

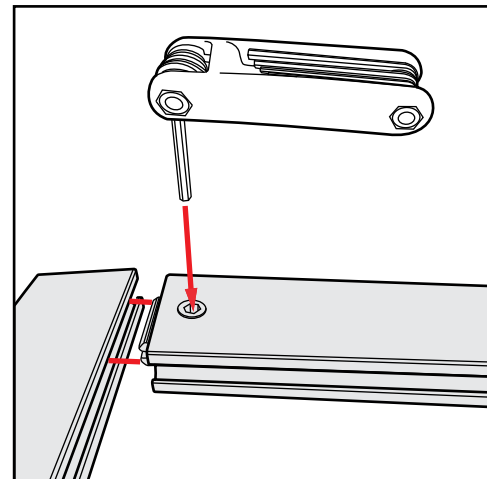

Extrusion & Lock Connection

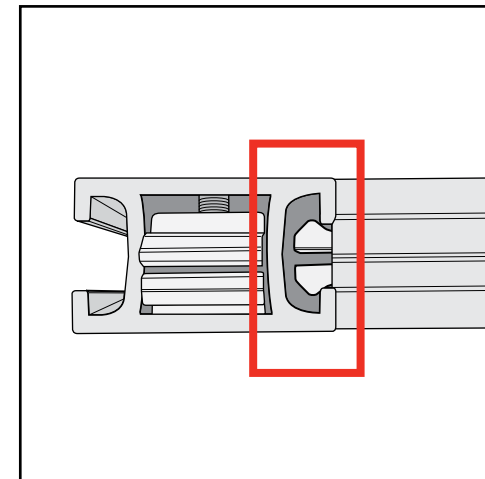

Engaged Lock



WARNING

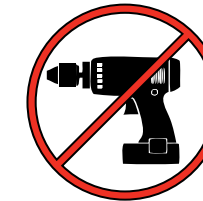

DO NOT USE POWER TOOLS



LADDERS OR LIFTS
MAY BE REQUIRED



ALL CONNECTIONS MUST
BE TIGHTLY SECURED

SEG Graphic Installation *in 3 Steps*

The Perfect Fit

STEP 1: Attach Corners

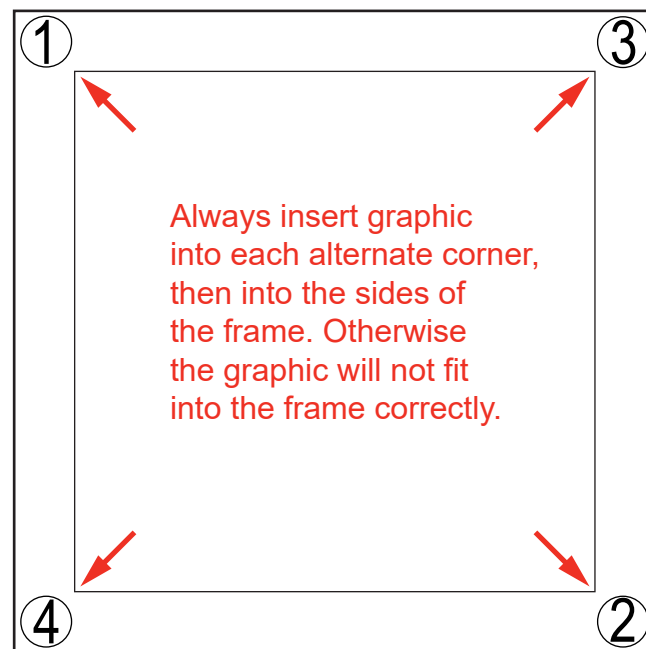

STEP 2: Attach Middle

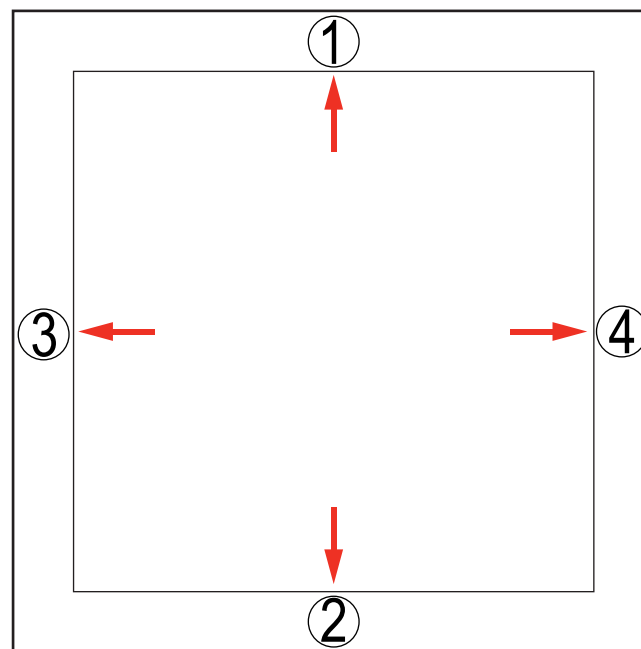

STEP 3: Attach Sides

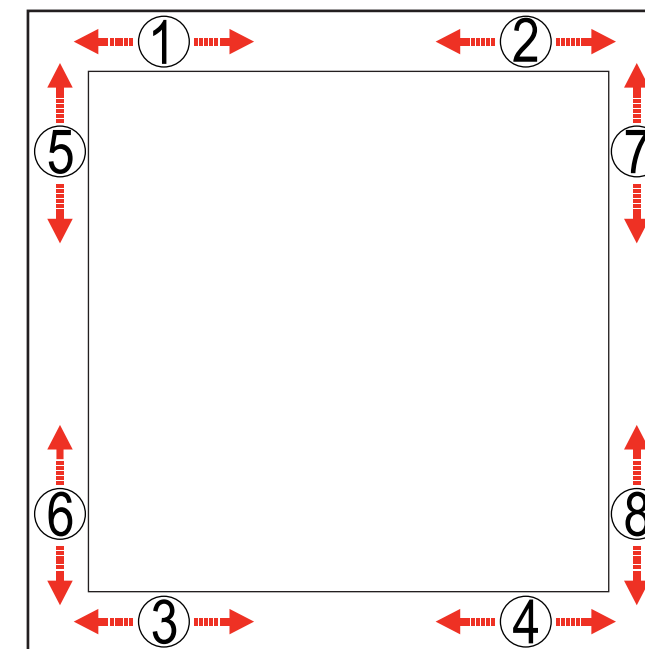

Insert narrow side of silicone welt into the channel at corner 1, with fabric to the outside.

Repeat for opposite corner 2, then corner 3, then corner 4.

Once corners are attached, press the middle of edge 1 into the channel. Then press middle of edge 2 into the channel on opposite side.

Repeat with edge 3 & 4.

Once the middle of sides are attached, fully press the silicone welt into the channel, between center and corner at location 1. Repeat the process between center and corner at location 2.

Do the same for welt on opposite side, at locations 3 & 4. Then repeat for locations 5 & 6 and 7 & 8.

Once the welt is fully inserted on all sides, smooth out edges as needed for a perfect fit.



To remove the graphic from the frame, locate the fabric **pull tab**. Gently pull on the tab to remove the graphic.

Install video:



CRATE PACKING

Item	Qty.	Description
1	1	Base Plate
2	1	70" CEI110 Horizontal Extrusion
3	1	70" CEI110 Angled Extrusion
4	1	25" CEI110 Angled Extrusion
5	1	70" CEI110 Angled Extrusion
6	1	25" CEI110 Angled Extrusion
7	1	70" CEI110 Horizontal Extrusion

- Steps:
- 1) Attach base plate [1] to horizontal [2], using bolt.
 - 2) Assemble extrusions together, as shown.
See [60° Corner Connection](#) detail.
 - 3) Install SEG graphic to assembled frame.
See SEG Installation sheet for instruction.

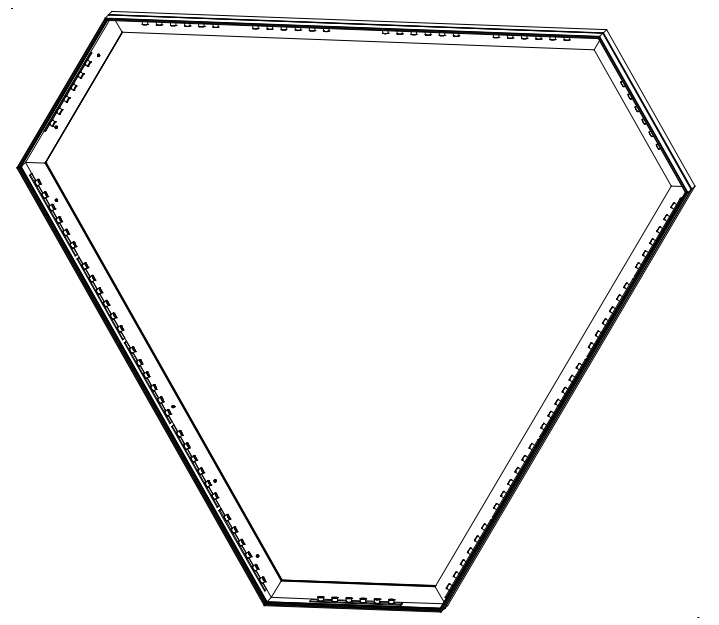

Completed Assembly

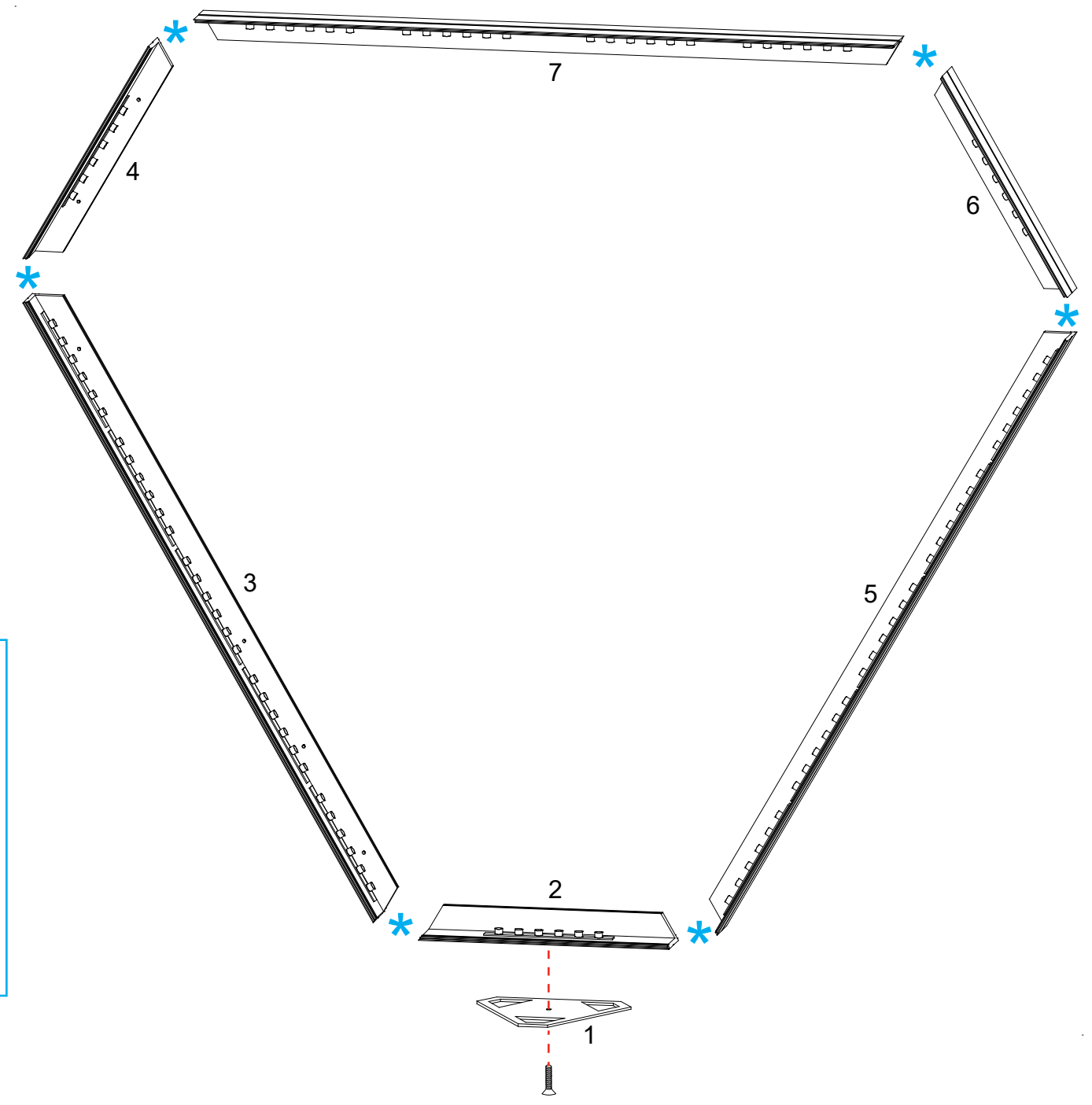

FRONT VIEW

*** 60° Corner Brackets**

- 1) Insert TSRV2 and A1 brackets into grooves of CEI110.
- 2) Slide connecting CEI110 over exposed end of brackets.
- 3) Tighten all set screws to secure.

Steps:

1) Attach clamps to angled extrusions [3] and [5] then connect wings. See [Clamp Attachment](#) detail.

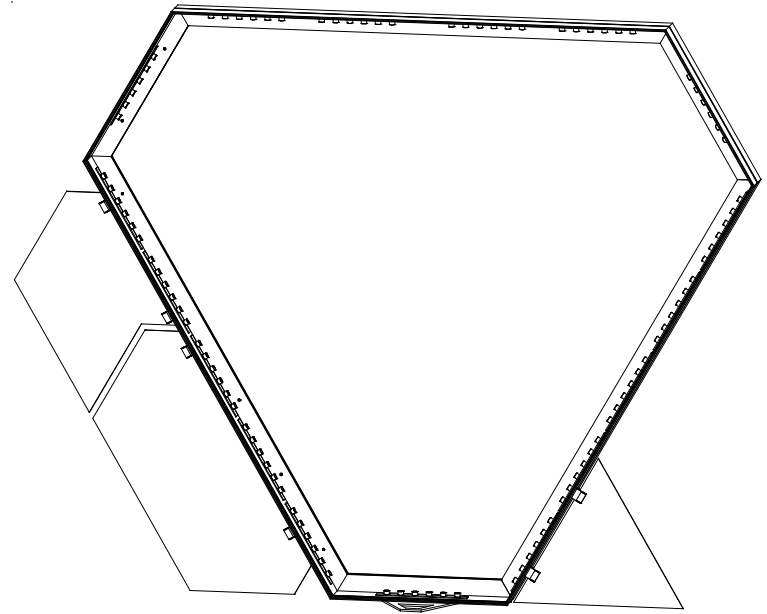

Completed Assembly

*** Clamp Attachment**

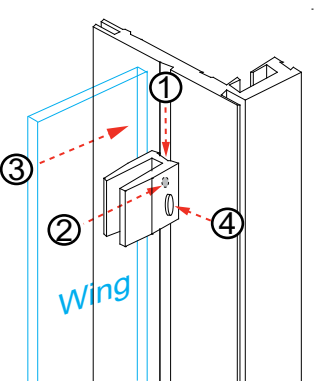

- 1) Slide clamp into groove of extrusion.
- 2) Tighten set screw to secure clamp to extrusion.
- 3) Insert wing into clamp.
- 4) Tighten knob to secure wing in place.

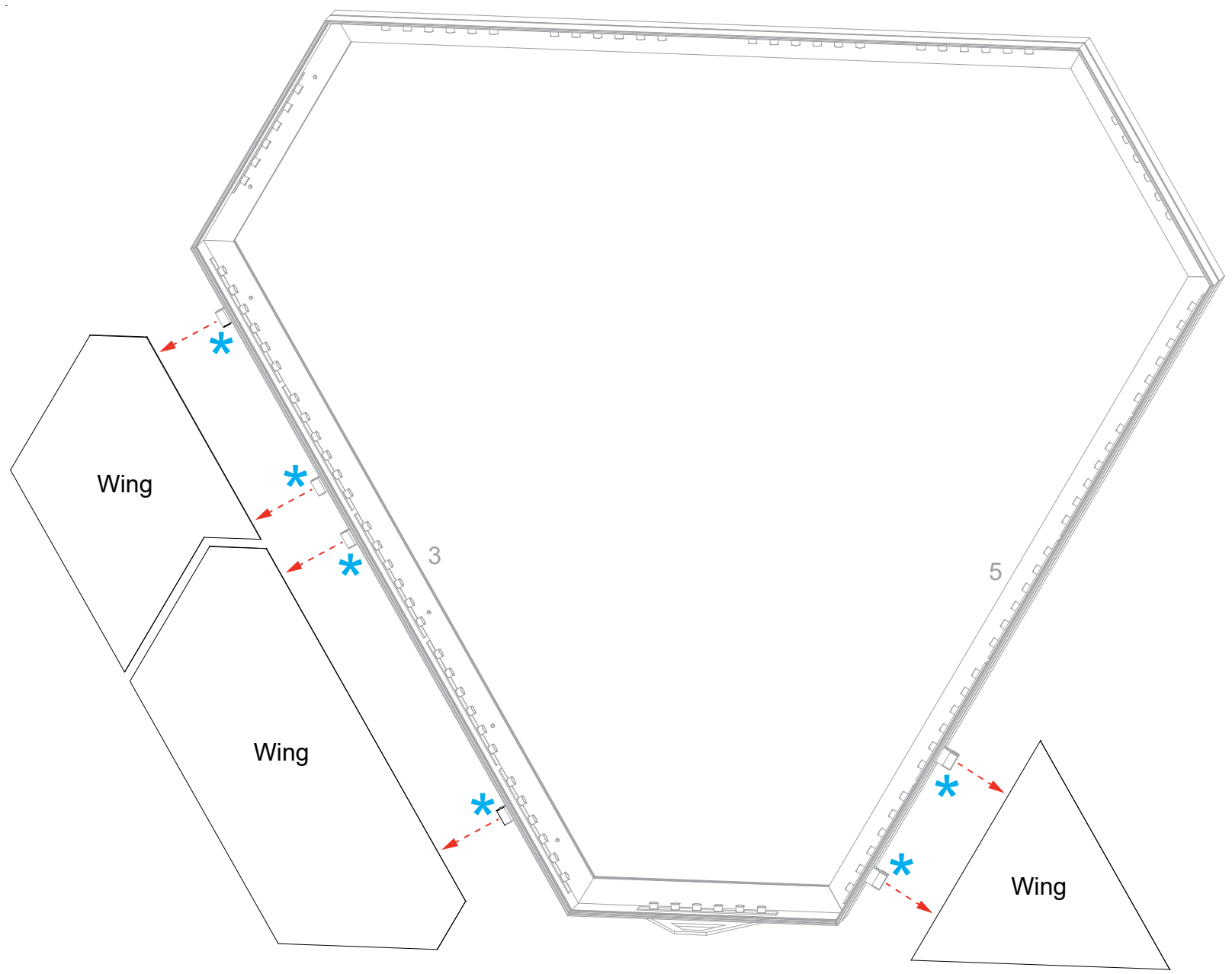

FRONT VIEW

Item	Qty.	Description
8	1	40.5" Q914 Vertical Extrusion
9	1	30" Q914 Vertical Extrusion

- Steps:
- 1) Connect verticals [8] and [9] together.
 - 2) Attach assembled verticals [8/9] to assembled workstation floor, using bolt.
 - 3) Attach monitor mount to vertical [9]. See [Monitor Mount](#) detail.
 - 4) Attach bracket to angled vertical [3], using screw caps.
 - 5) Attach workstation to bracket, using standoffs and screw caps.
 - 6) Attach monitor then route cord through conduit.
See [Cord Management](#) detail.

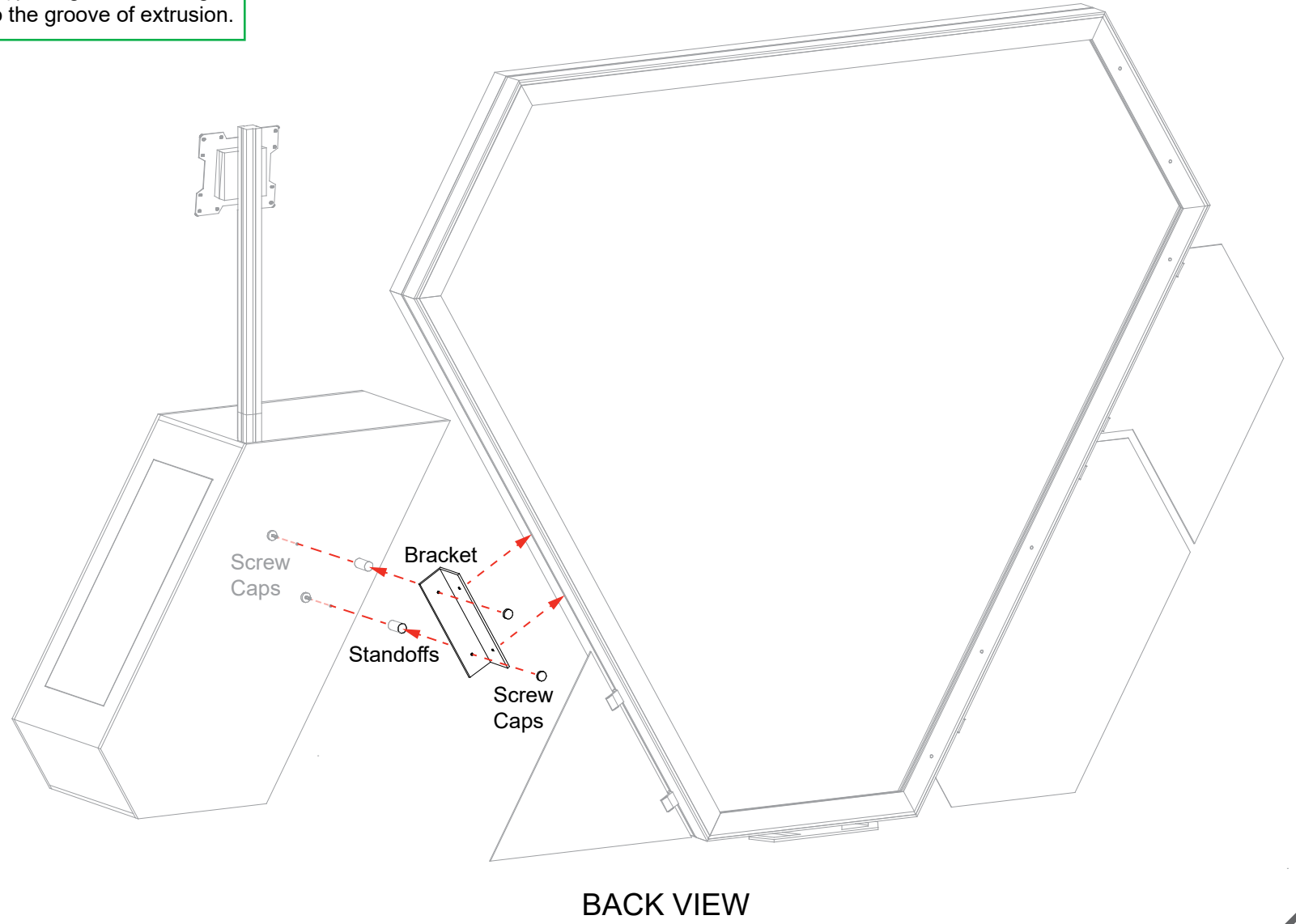
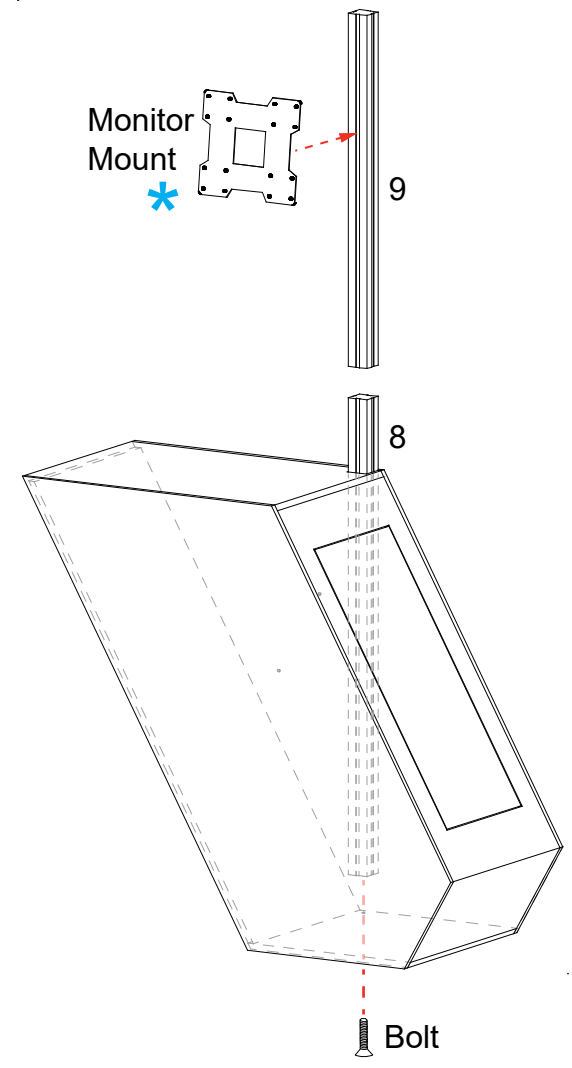
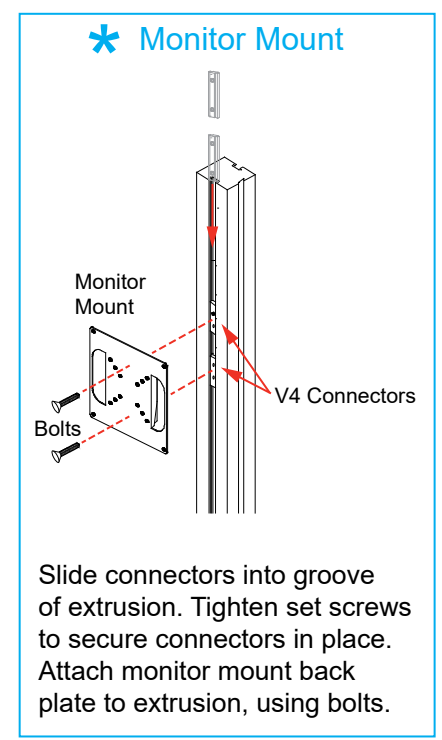
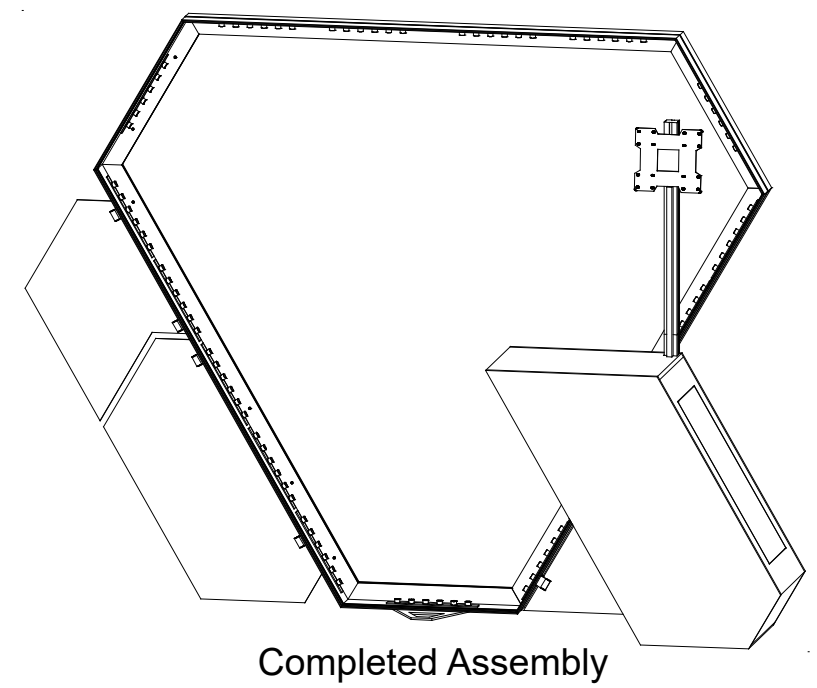
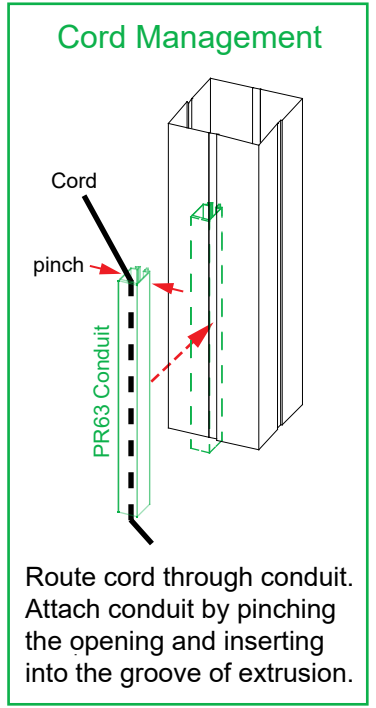

Item	Qty.	Description
1	1	38" h Corner Connector
2	1	19" w x 38" h Panel w/ Door
3	1	38" h Corner Connector
4	1	19" w x 38" h Panel
5	1	38" h Corner Connector
6	1	19" w x 38" h Panel
7	1	38" h Corner Connector
8	1	19" w x 38" h Panel

- Steps:**
- 1) Connect panels and connectors together in numerical order, making sure the Velcro is facing inward.
 - 2) Connect shelf supports to Velcro on panels.
 - 3) Place shelf on shelf supports.
 - 4) Attach graphic to panel [6]. See **Graphic Attachment** detail.
 - 5) place pedestal top onto assembled pedestal.

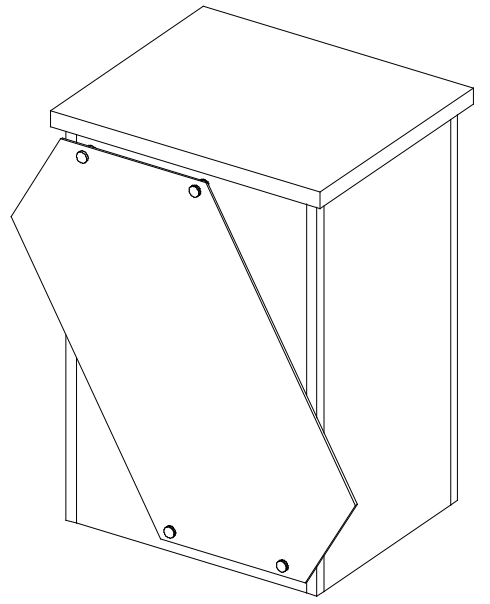
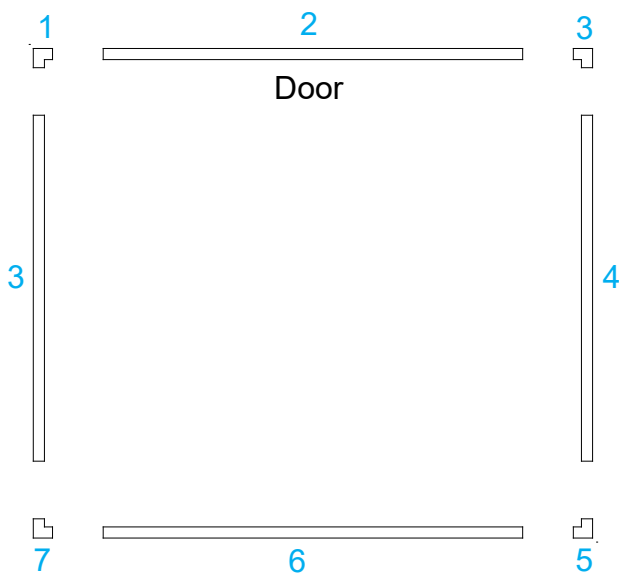

Completed Assembly

