

PLAN VIEW

10'

10'

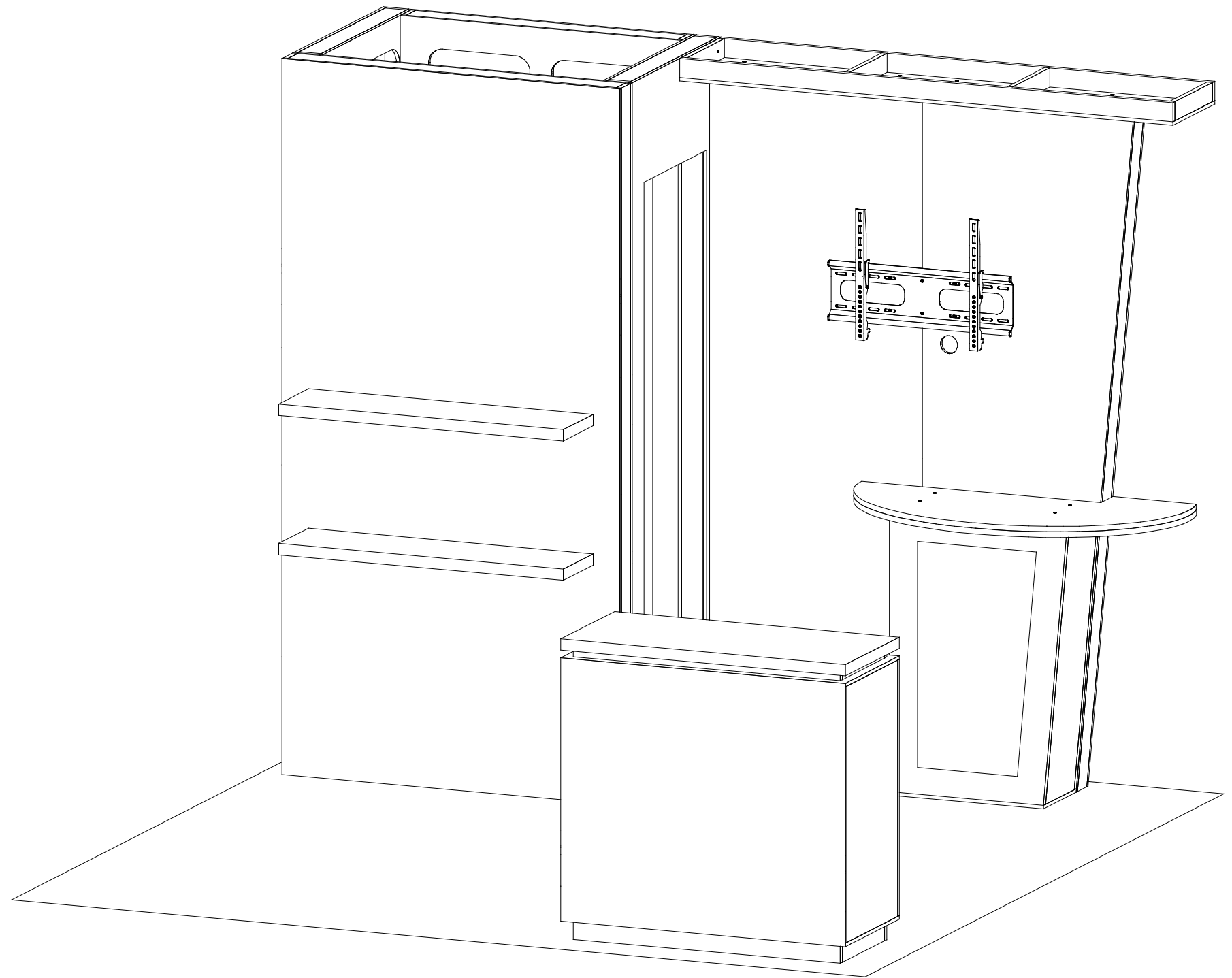

SETUP INSTRUCTIONS

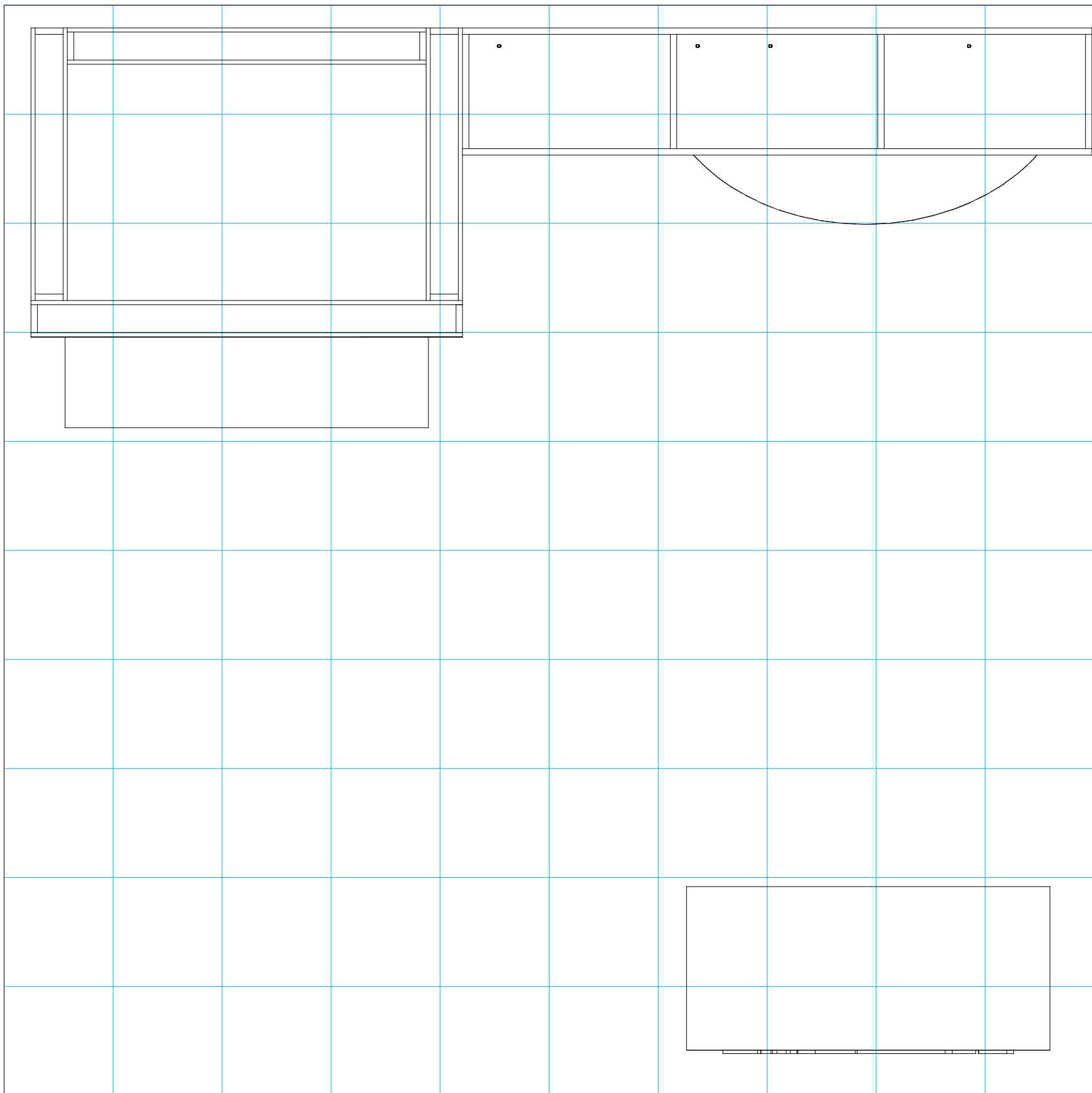

= 1 sq foot

General Setup Instructions

- Read entire setup instruction manual prior to unpacking parts and pieces.
- The setup instructions are created specifically for this configuration.
- Setup instructions are laid out sequentially in steps, including exploded views with detailed explanation for assembly.

Cleaning & Packing

- For Cleaning Metal, Plex, & Laminate Parts: Use a **MILD NON-ABRASIVE** cleanser and soft cloth/paper towel to clean all surfaces.
- Keep exhibit components away from heat and prolonged sun exposure. **Heat and UV exposure will warp and fade components.**
- Retain all provided Packing Materials. All provided packing materials are for ease of repacking & component protection.

Disassembly

- For loss prevention, tighten all set screws and locks during disassembly.

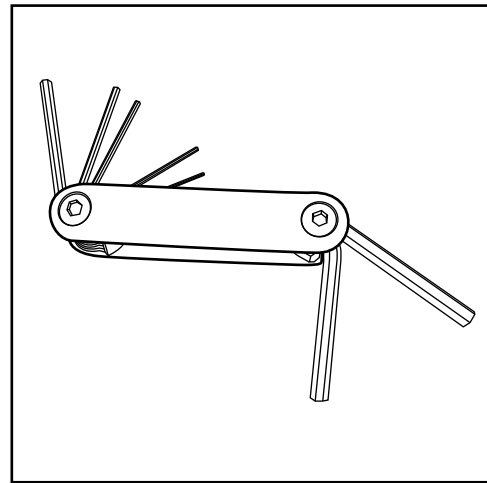

Hex Tool - Essential for Assembly

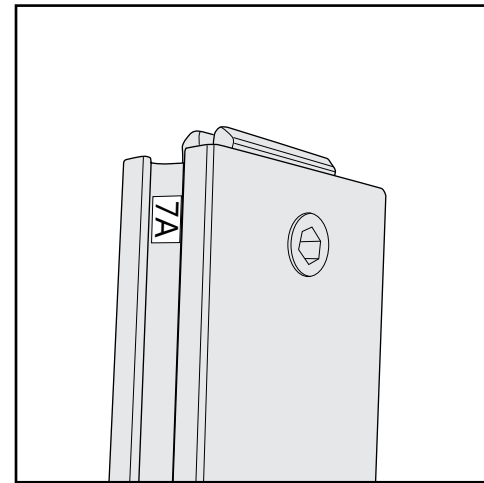

Part Identification - Numbering

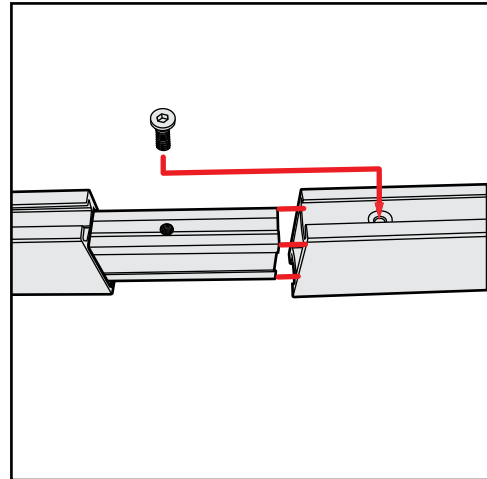

Spline Connection

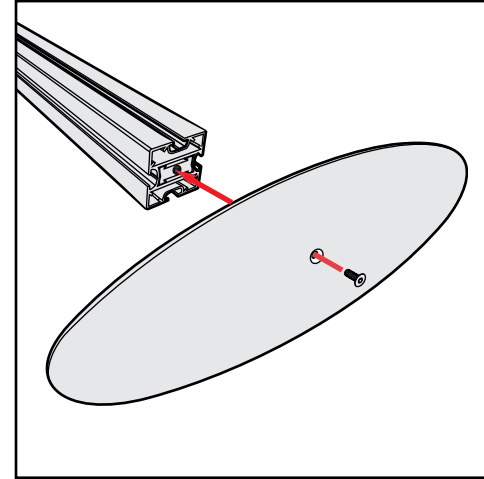

Base Plate & Extrusion Connection

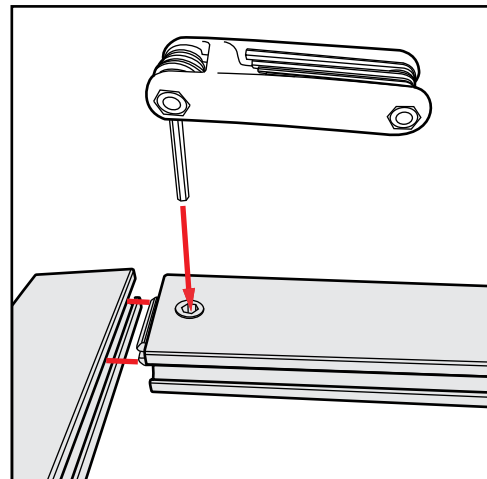

Extrusion & Lock Connection

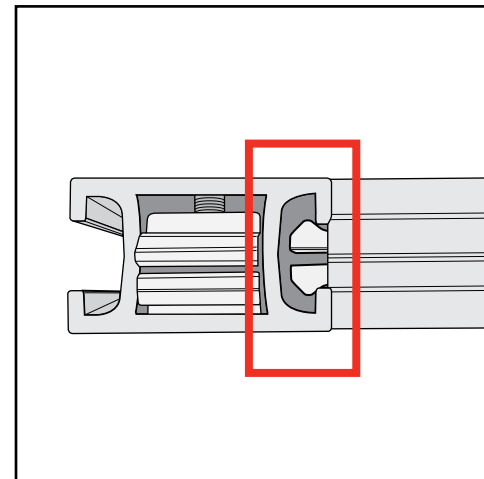

Engaged Lock



WARNING



DO NOT USE POWER TOOLS



LADDERS OR LIFTS
MAY BE REQUIRED



ALL CONNECTIONS MUST
BE TIGHTLY SECURED

CRATE PACKING

| Item | Qty. | Description |
|------|------|--|
| A | 1 | 30"w x 4"d x 95"h Side Panel |
| B | 1 | 39.5"w x 4"d x 95"h Back Panel |
| C | 1 | 30"w x 4"d x 95"h Side Panel w/ Door |
| D | 1 | 47.5"w x 4"d x 95"h Front Panel w/ Logo |
| E | 1 | 29.866"w x 4"d x 92"h Backwall Panel |
| F | 1 | 29.866"w x 4"d x 92"h tapered Backwall Panel |

Steps:
1) Assemble panels [A] through [F] together as shown using roto cam locks. See **Roto Cam Lock Connection** detail.

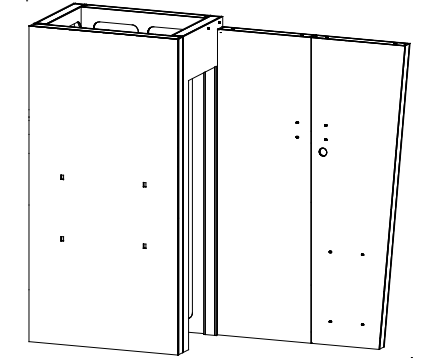

When assembled

*** Roto Cam Lock Connection**

Step 1

Step 2

Place hex tool in hole on side of panel. Rotate to activate lock & secure panels together.

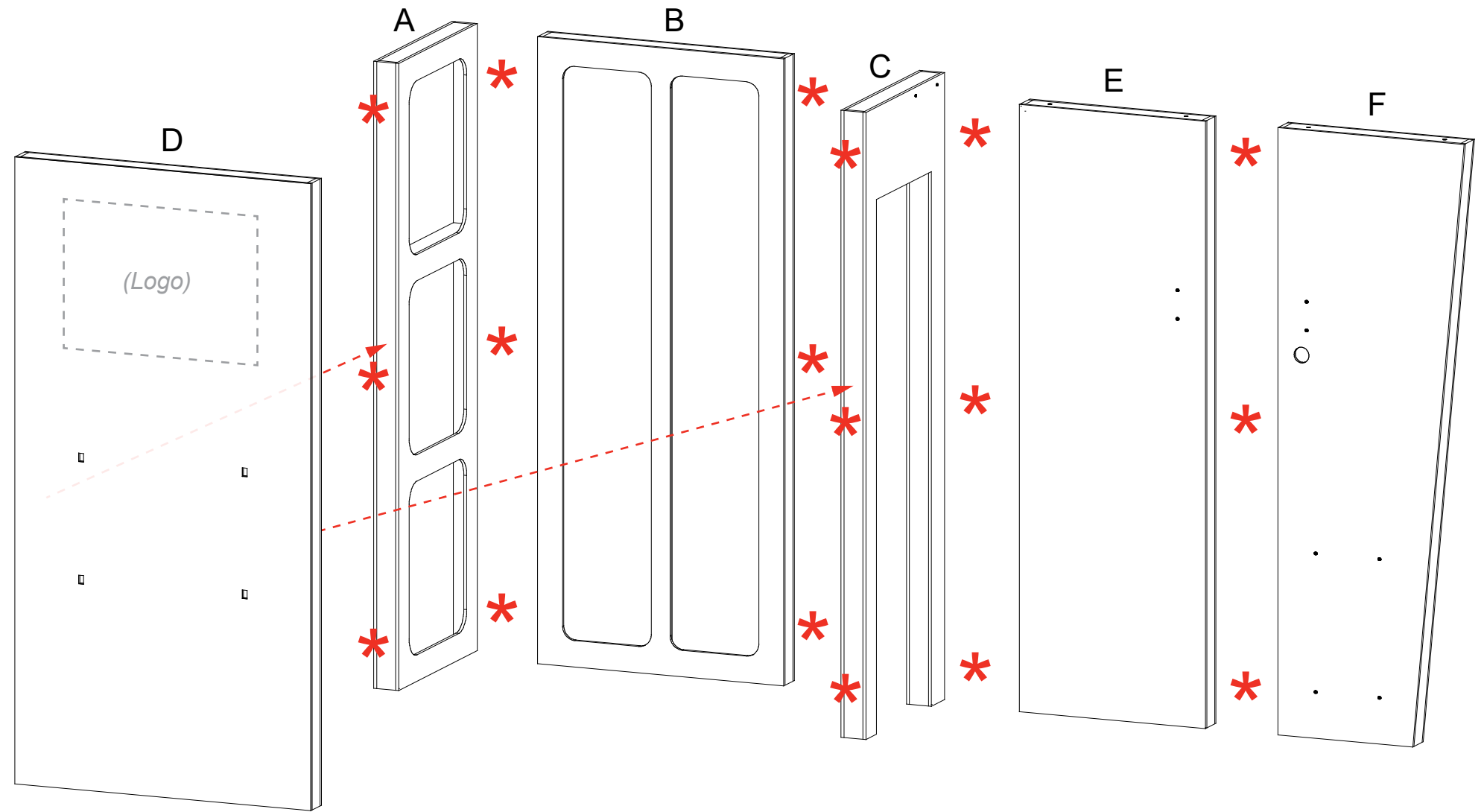
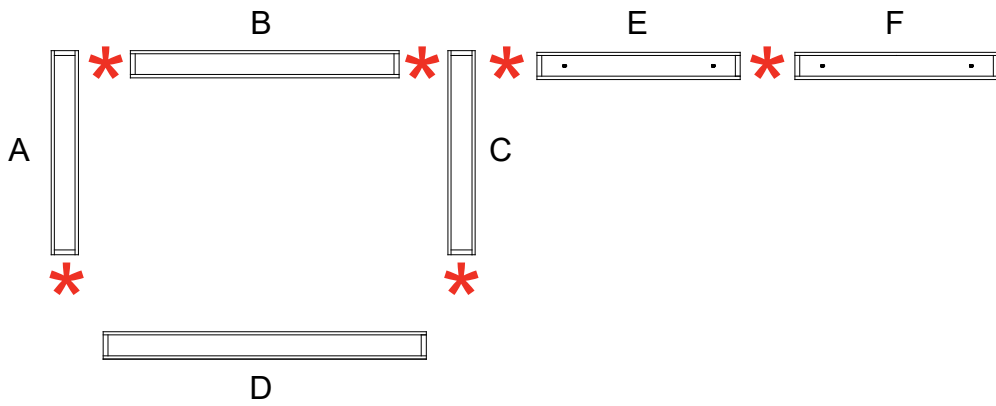

FRONT VIEW

| Item | Qty. | Description |
|------|------|--------------------------------|
| -- | 2 | 40"w x 10"d Shelf w/ cam locks |

- Steps:
- 1) Attach Shelves to front of panel [D]. See **Roto Cam Lock Connection** detail.
 - 2) Connect power cords to **LED lights** behind logo in panel [D]

*** Roto Cam Lock Connection**

Step 1



Hex Key Tool
Hole

Step 2



Hex Key Tool
Lock

Place hex tool in hole on side of panel. Rotate to activate lock & secure panels together.

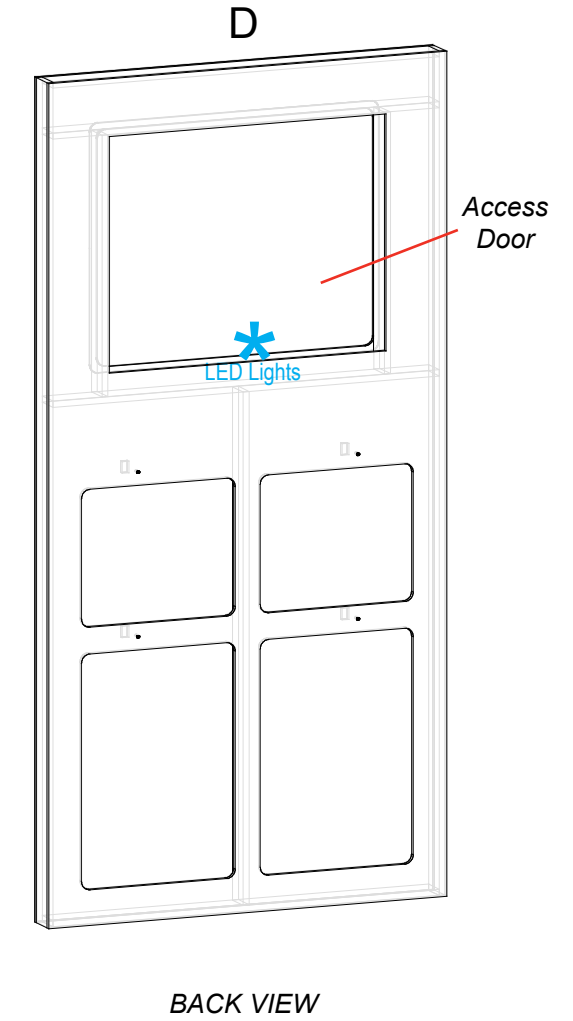
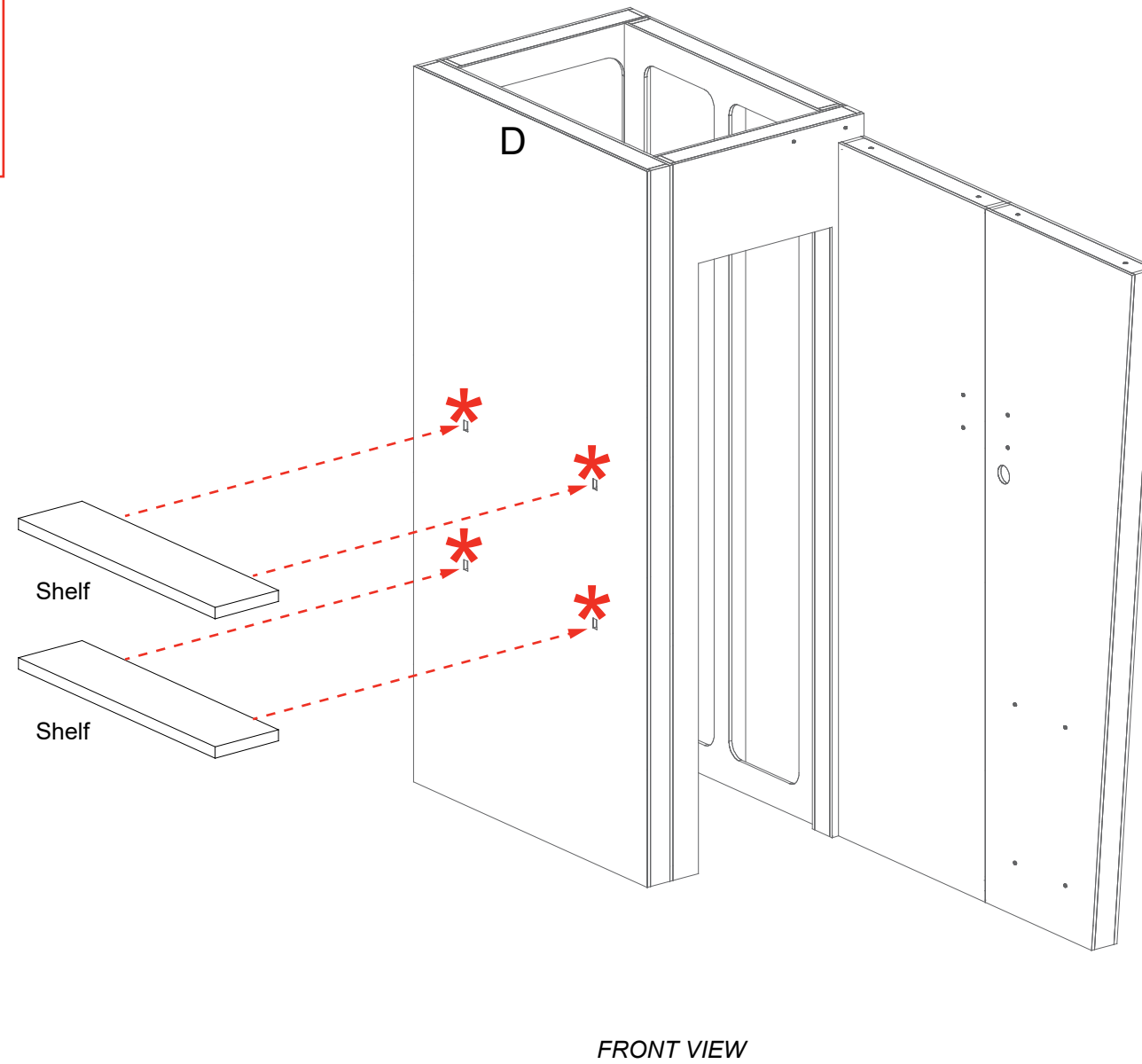

*** LED Power Cord Attachment**

Connect transformer to LED Controller. Then connect transformer to power source.

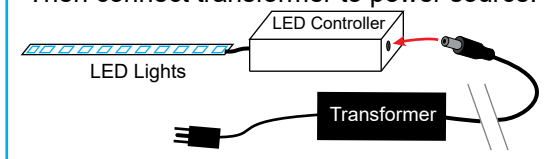

| Item | Qty. | Description |
|------|------|------------------------------------|
| G | 1 | 69.294"w x 14"d x 3"h Canopy panel |

Steps:
1) Attach Canopy [G] to top of panels [E/F] & attach to side of panel [C] using **Bolt to T-Nut Connection**.

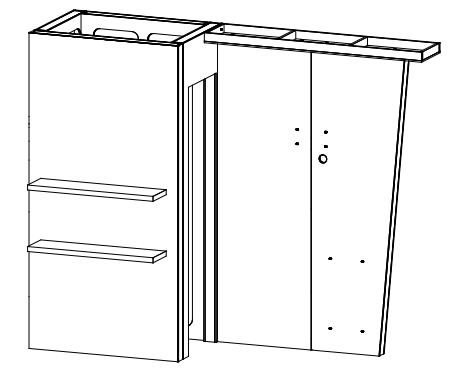

When assembled

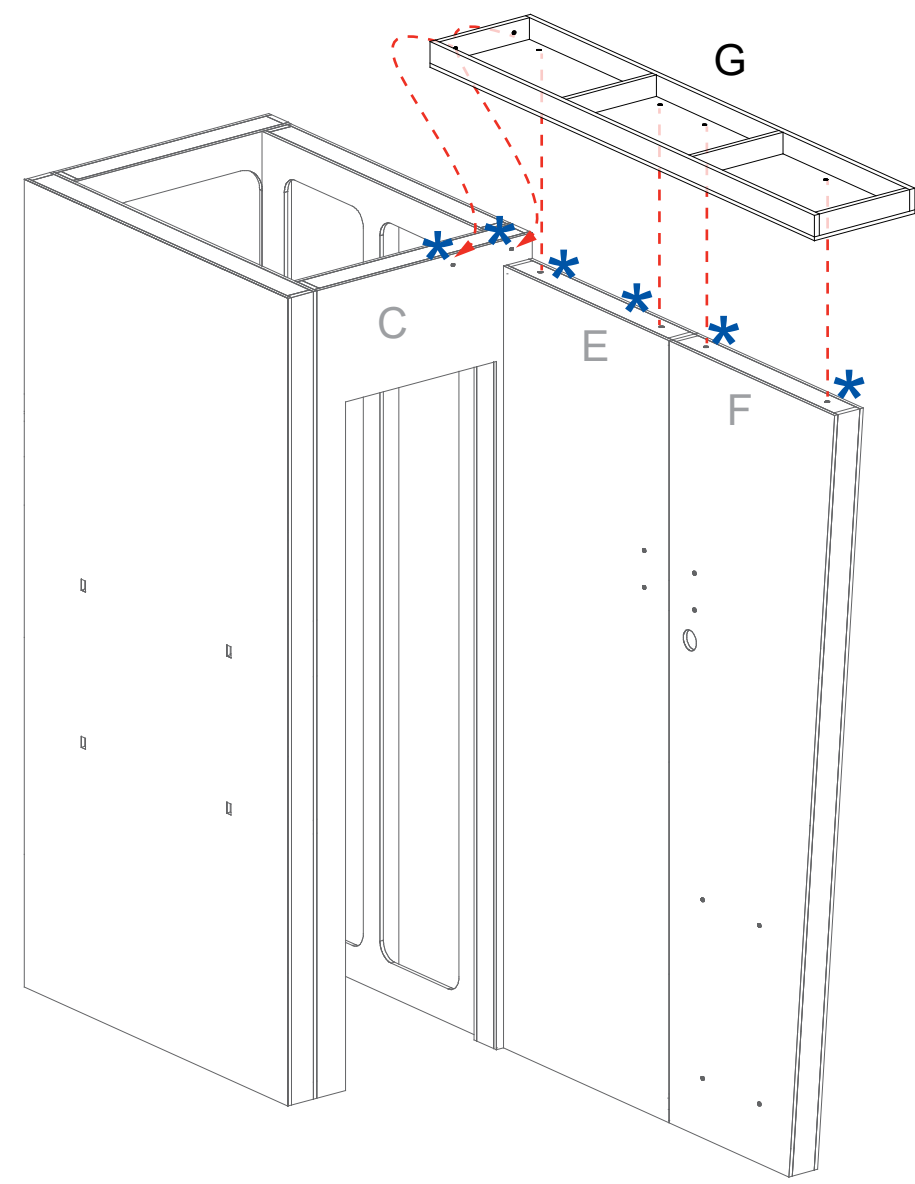
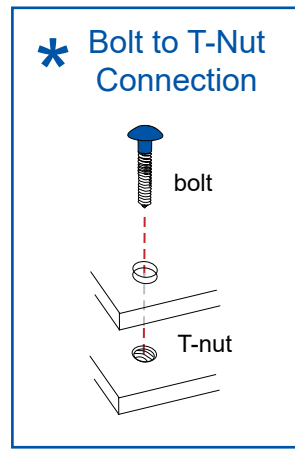

FRONT VIEW

| Item | Qty. | Description |
|------|------|-------------------------------------|
| H1 | 1 | 25.034"w x 11"d x 38"h Counter Base |
| H2 | 1 | 45.907"w x 21.611"d Counter Top |
| -- | 1 | Large Monitor Mount |

- Steps:
- 1) Attach Counter Top [H1] to Counter Base [H2] as shown.
 - 2) Connect Counter Base [H2] to backwall panels [E/F] using **Bolt to T-Nut Connection**.
 - 3) Install Monitor Mount to backwall panels [E/F]. See **Monitor Mount Attachment** detail.

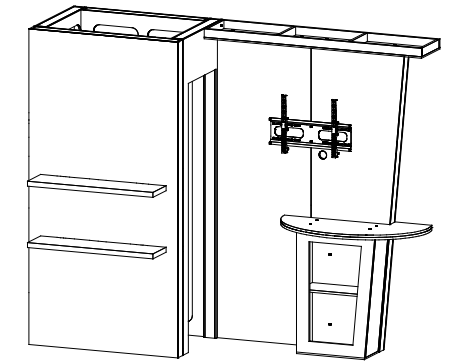

When assembled

Counter Top Attachment

Insert threaded pin into T-nut on underside of counter top. Twist pin to tighten in place.

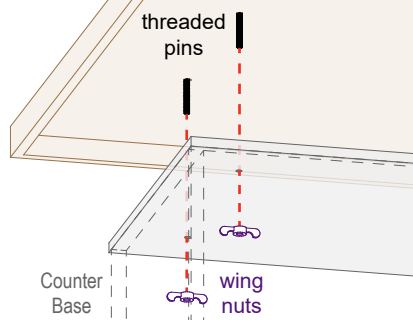

Insert pins through holes in top of counter base. Secure using wing nuts from inside counter base.

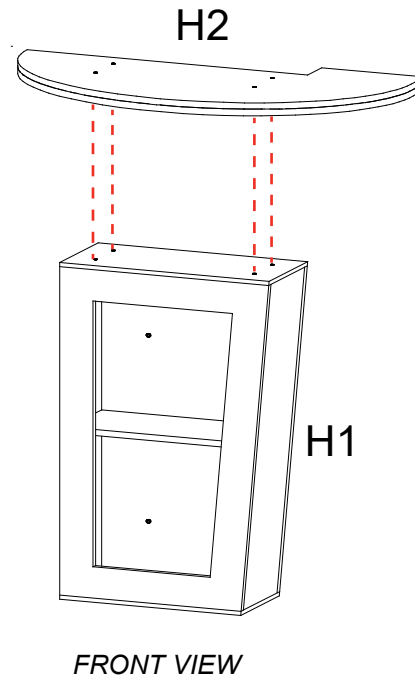

FRONT VIEW

*** Bolt to T-Nut Connection**

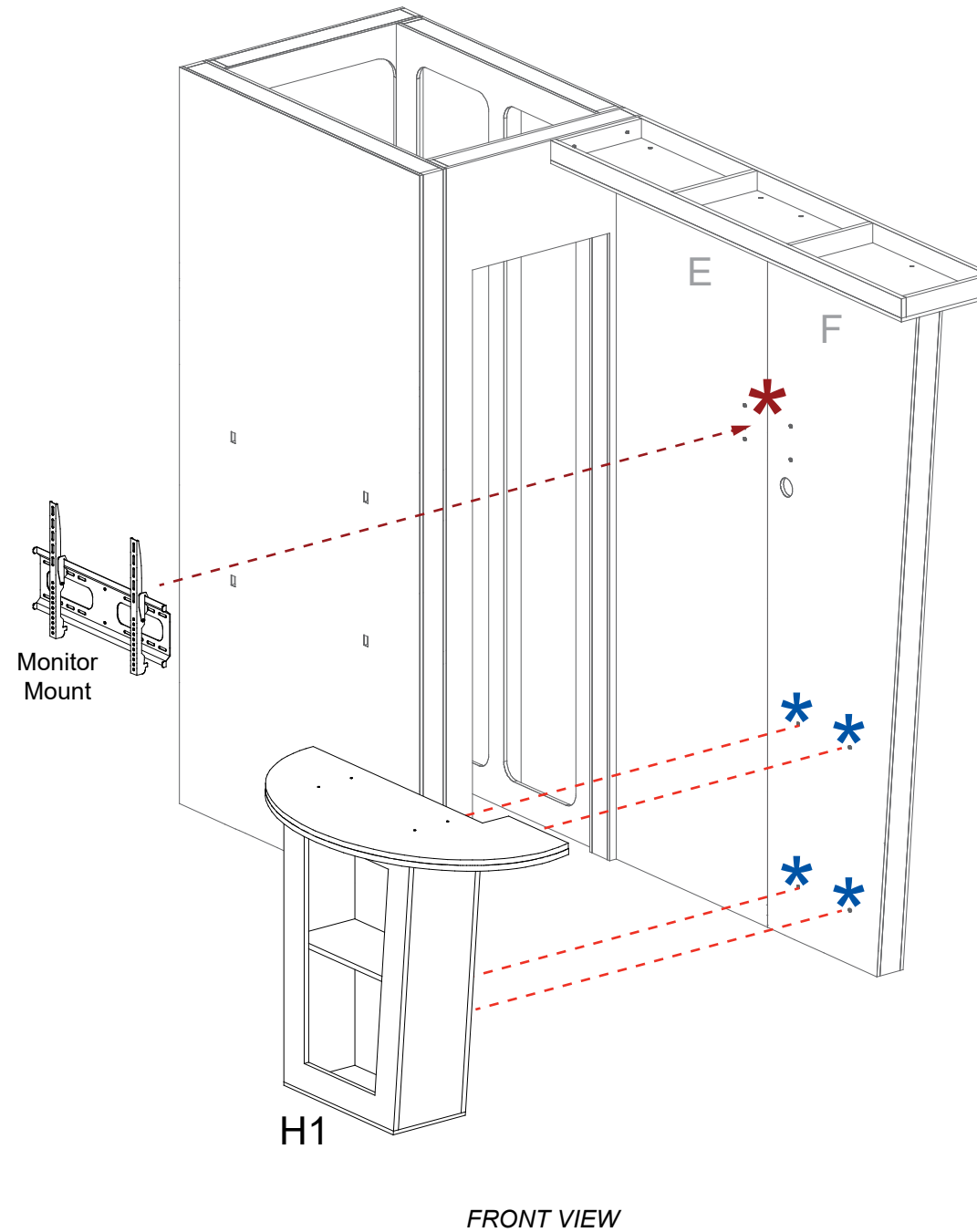
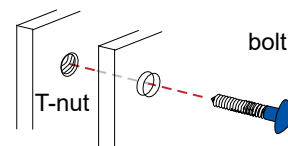

FRONT VIEW

*** Monitor Mount Attachment**

Insert bolts through Monitor Mount to T-nuts in backwall. Tighten bolts to secure in place.

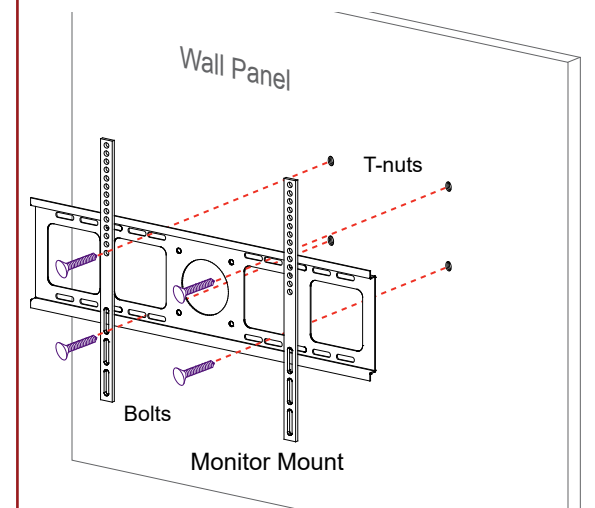

| Item | Qty. | Description |
|------|------|---|
| -- | 1 | 40"w x 18"d x 40"h MOD-1581 Reception Counter |

Steps:
1) Connect power cords to **LED lights** behind logo.

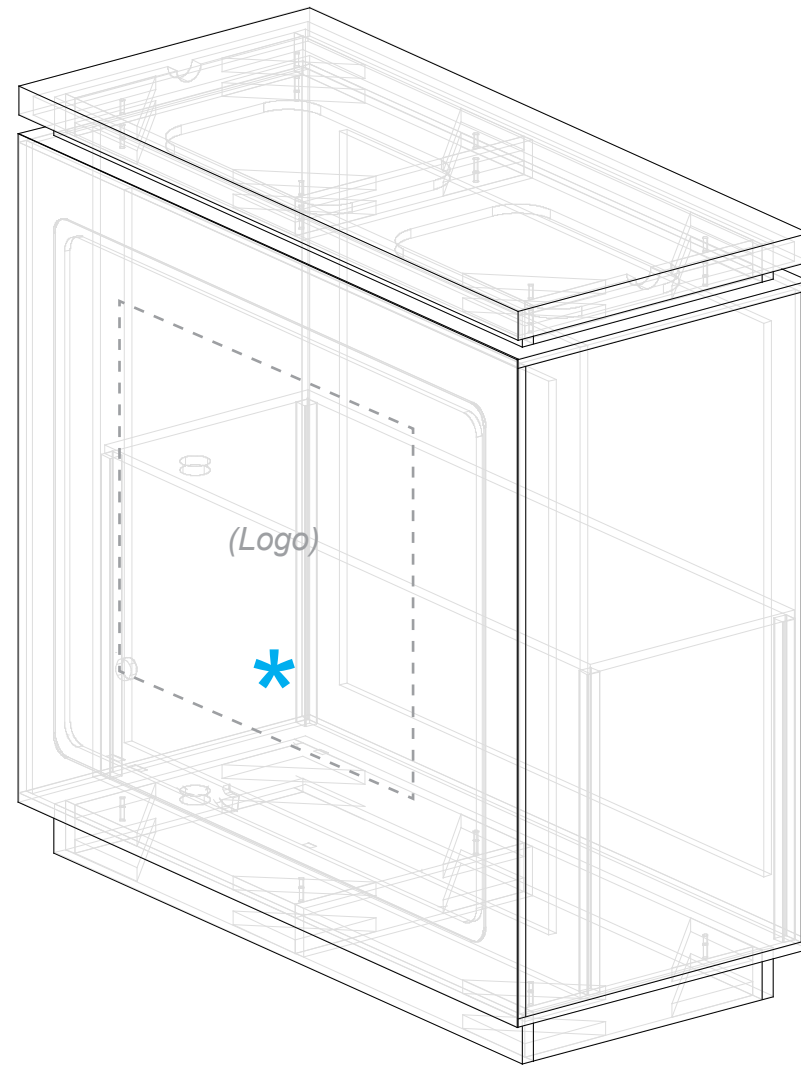

FRONT VIEW

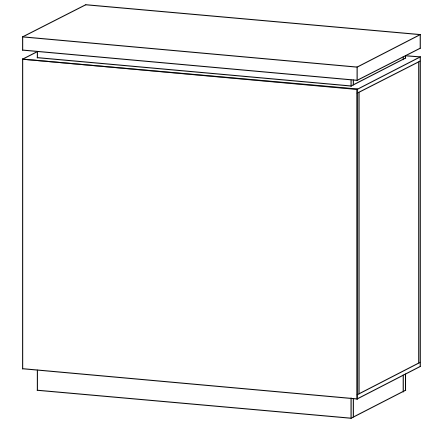

When assembled

FRONT VIEW

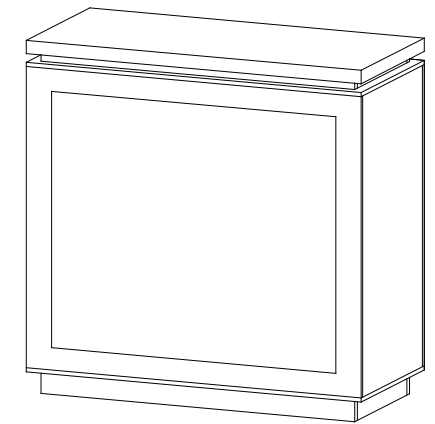

BACK VIEW

*** LED Power Cord Attachment**
Connect transformer to LED Controller.
Then connect transformer to power source.